

DIN 912 IMBUS / DIN 7990 / DIN 7991 / DIN 6914 / DIN 6915 / DIN 961 / DIN 960 / DIN 975 / DIN 936 / DIN 916 / ASA B18.2.1 / ASA B18.2.2 SOMUN / DIN 937

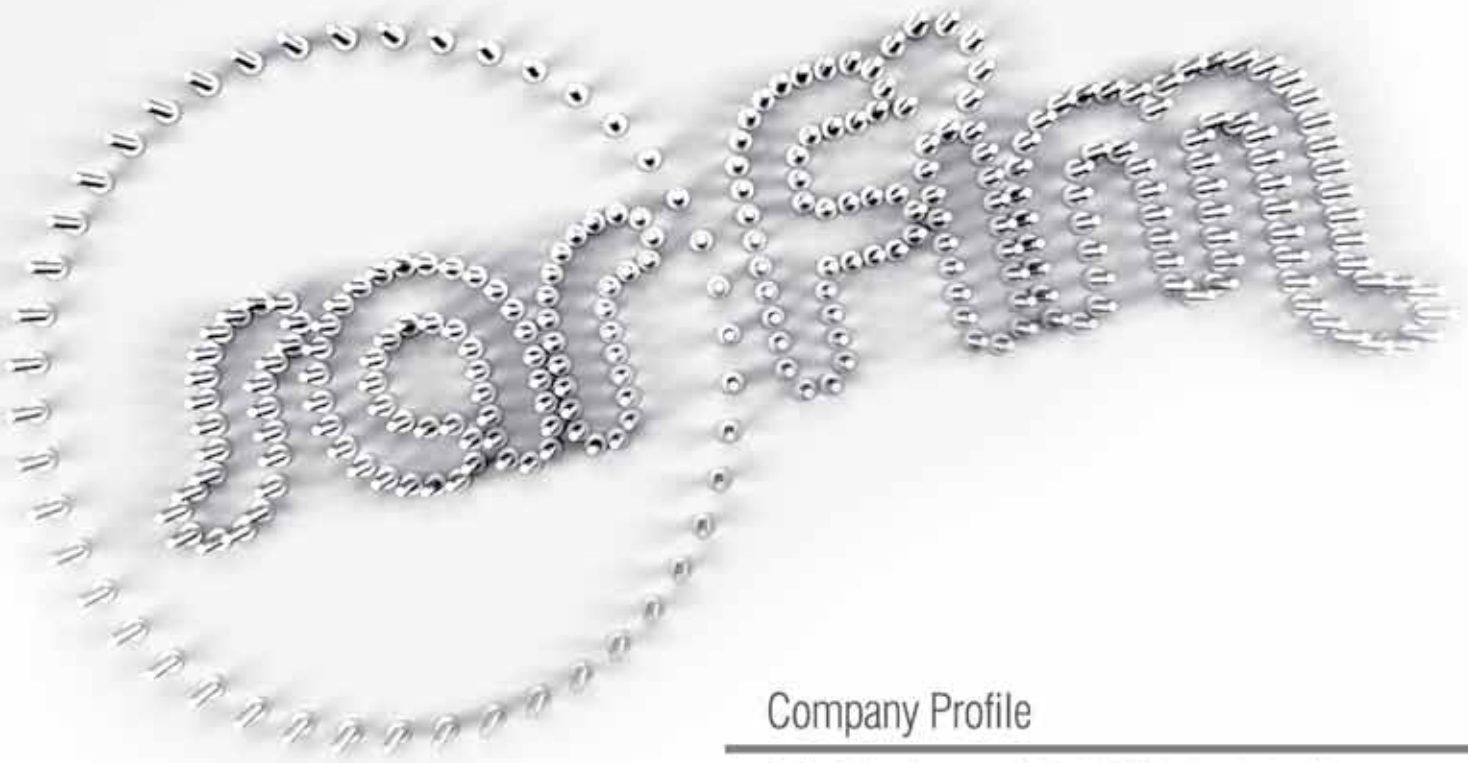

BOLT&NUT CATALOGUE
CİVATA & SOMUN KATALOĐU



Company Profile

Sarfim Automotive was established in 2000 for the production of fastener.

- Our products are manufactured according to M16&M56 specifications conforming to international standards and special norms

- Raw materials used at the production are bought from well-known and reputed companies.

- We become a powerful company in its sector increasing the production capacity and investing human sources.

- Our facilities are updated considering the market requirements.

- Our company has been awarded **ISO 9001:2008** by **TUV CERT.**

- We aim to be the best manufacturer and supplier of all sort of fasteners and bolts in local and international markets providing competitive prices and quality parts on time.



Firma Profili

- **Sarfim Otomotiv** bağlantı ekipmanları üretmek üzere 2000 yılında kurulmuştur.

- Şirketimiz, insan kaynaklarına ve teknolojiye yaptığı yatırımlar ile üretim kapasitesini artırarak sektöründe güçlü bir konuma gelmiştir.

- Firmamız **TUV ISO 9001:2008** kalite belgesi ile faaliyetlerini sürdürmektedir.

- Ürünlerimiz M16&M56 ölçü değerlerinde uluslararası standartlara ve ayrıca özel formlara uygun olarak üretilmektedir.

- Üretim ve hizmetlerimiz değişen piyasa şartları gözönünde bulundurularak, kalite sistemimizden taviz vermeden müşteri memnuniyeti esas alınarak ve sürekli güncellenerek devam etmektedir.



www.sarfim.com

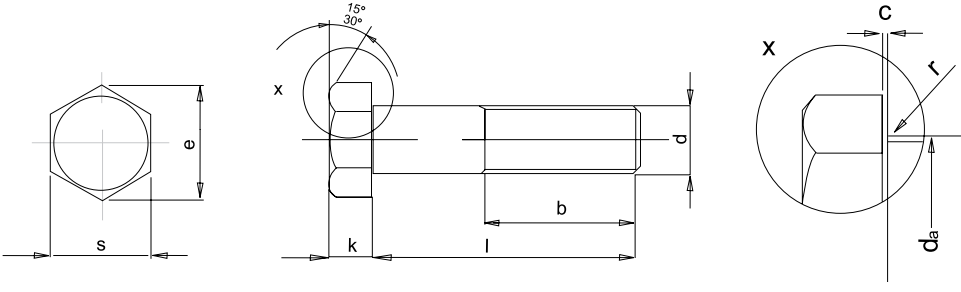

DIN 931

ALTI KÖŞE BAŞLI CİVATALAR
HEXAGON HEAD BOLTS

Kalite Yönetimi / Quality Management: ISO 4014 / 4017

Kalite / Quality : 5.6/5.8/ 8.8/10.9/12.9

TABLODAKİ TÜM DEĞERLER MİLMETRE OLARAK VERİLMİŞTİR. / ALL VALUES IN TABLE ARE GIVEN IN MILIMETERS

THREAD SIZE / ANMA ÇAPI	M16	M18	M20	M22	M24	M27	M30	M33	M36	M39	M42	M45	M48	M52	M56
PITCH / DİŞ ADIMI	P	2,00	2,50	2,50	2,50	3,00	3,00	3,50	3,50	4,00	4,00	4,50	4,50	5,00	5,00
HEAD HIGH / KAFA YÜKSEKLİĞİ	k	10	12	13	14	15	17	19	21	23	25	26	28	30	33
HEAD WITH / ANAHTAR AĞZI	S	24	27	30	32	36	41	46	50	55	60	65	70	75	80
DIAGONEL / KÖŞEGEN	e	26,75	30,14	33,53	35,72	39,98	45,63	51,28	55,8	61,31	66,96	72,61	78,26	83,91	89,56
THREAD LENGHT / DİŞ UZUNLUĞU	b1	38	42	46	50	54	60	66	72	78	84	90	96	102	-
	b2	44	48	52	56	60	66	72	78	84	90	96	102	108	116
	b3	57	61	65	69	73	79	85	91	97	103	109	115	121	129

b1: thread lengths for bolts till 125mm / 125mm. Boya kadar olan civatalar için diş boyu

b2: thread lengths for bolts between 125mm-200mm / 125mm-300mm. Boylar arasındaki civatalar için diş boyu

b3: thread lengths for bolts more than 200mm/ 200mm den uzun boylu civatalar için diş boyu

THREAD SIZE / ANMA ÇAPI	M16	M18	M20	M22	M24	M27	M30	M33	M36	M39	M42	M45	M48	M52	M56
LENGHT OF BOLT	1000 ADETİN KG AĞIRLIĞI / MASS FOR 1.000 UNITS IN KG														
50															
55	115														
60	123	161													
65	131	171	219												
70	139	181	231	281											
75	147	191	243	296	364										
80	155	201	255	311	382	511									
85	163	210	267	326	410	534									
90	171	220	279	341	428	557	712								
95	179	230	291	356	446	580	739								
100	186	240	303	370	464	603	767	951							3400
110	202	260	327	400	500	650	823	1020	1250	1510					3590
120	218	280	351	430	535	695	880	1090	1330	1590	1900	2260			3780
130	230	295	365	450	560	720	920	1150	1400	1650	1980	2350	2780		3970
140	246	315	398	480	595	765	975	1220	1480	1740	2090	2480	2920		4160
150	262	335	423	510	630	810	1030	1290	1560	1830	2200	2600	3010	3450	4360
160	278	355	447	540	665	855	1090	1350	1640	1930	2310	2730	3160	3770	4550
170	294	375	470	570	700	900	1140	1410	1720	2020	2420	2850	3300	3930	4740
180	310	395	495	600	735	945	1200	1480	1900	2120	2520	2980	3440	4100	4930
190	326	415	520	630	770	990	1250	1540	1980	2210	2630	3100	3580	4270	5120
200	342	435	545	660	805	1030	1310	1610	2060	2310	2740	3220	3720	4430	5300
220			590	720	870	1130	1420	1750	2220	2500	2960	3470	4010	4760	5660
240					940	1230	1530	1880	2380	2700	3180	3820	4290	5110	6030
260						1310	1640	2020	2540	2900	3400	4030	4570	5450	6410
280							1750	2150							6800
300							1860	2290							7190
320															
340															
360															
400															

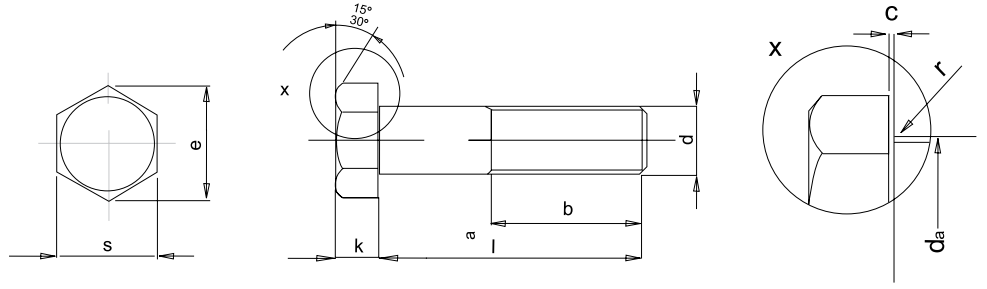

DIN 933

ALTI KÖŞE BAŞLI TAM DİŞLİ CİVATALAR

HEXAGON HEAD BOLTS THREADED UP TO HEAD

Kalite Yönetimi / Quality Management: ISO 4014 / 4017

Kalite / Quality :5.6/5.8/ 8.8/10.9/12.9

TABLODAKİ TÜM DEĞERLER MİLİMETRE OLARAK VERİLMİŞTİR. / ALL VALUES IN TABLE ARE GIVEN IN MILIMETERS

THREAD SIZE / ANMA ÇAPI	M16	M18	M20	M22	M24	M27	M30	M33	M36	M39	M42	M45	M48	M52	M56	
PITCH / DİŞ ADIMI	P	2,00	2,50	2,50	2,50	3,00	3,00	3,50	3,50	4,00	4,00	4,50	4,50	5,00	5,00	5,5
HEAD HIGH / KAFA YÜKSEKLİĞİ	k	10	12	13	14	15	17	19	21	23	25	26	28	30	33	35
HEAD WITH / ANAHTAR AĞZI	S	24	27	30	32	36	41	46	50	55	60	65	70	75	80	85
DIAGONEL / KÖŞEĞEN	e	26,75	30,14	33,53	35,72	39,98	45,63	51,28	55,8	61,31	66,96	72,61	78,26	83,91	89,56	95,07

THREAD SIZE / ANMA ÇAPI	M16	M18	M20	M22	M24	M27	M30	M33	M36	M39	M42	M45	M48	M52	M56
LENGHT OF BOLT	1000 ADETİN KG AĞIRLIĞI / MASS FOR 1.000 UNITS IN KG														
50	103	137	178	219	274	377	496	630	793	992	1180	1430	1710	2090	
55	110	146	188	232	289	397	519	659	827	1030	1230	1490	1770	2170	
60	117	154	199	244	304	416	543	688	861	1070	1270	1540	1830	2240	
65	123	162	209	257	319	435	566	717	896	1110	1310	1600	1890	2310	
70	130	170	219	269	334	454	590	746	930	1160	1370	1650	1950	2390	
75	137	178	229	282	348	473	614	775	964	1200	1420	1710	2020	2460	
80	144	187	240	295	363	492	637	806	1000	1240	1460	1760	2080	2540	
85	150	195	250	308	378	512	661	837	1030	1280	1510	1810	2140	2610	
90	157	203	260	321	393	531	685	866	1070	1320	1550	1870	2200	2680	
95	164	211	271	333	408	550	708	891	1100	1360	1600	1920	2260	2570	
100	170	219	281	346	423	569	732	920	1150	1400	1650	1980	2320	2830	
110	184	236	302	371	453	608	779	978	1210	1480	1740	2090	2450	2970	
120	197	252	322	397	483	647	827	1040	1270	1560	1840	2190	2870	3120	
130	210	269	343	421	513	685	874	1090	1340	1650	1930	2300	2690	3260	
140	224	285	364	448	543	724	921	1150	1410	1730	2020	2410	2820	3410	
150	237	301	384	473	572	762	969	1210	1480	1810	2120	2520	2940	3550	
160		317	404	498	602	801	1010	1270	1550	1890	2210	2630	3060	3700	
170		333	424	523	632	839	1060	1330	1620	1970	2300	2740	3190	3850	
180		349	444	548	662	875	1110	1390	1690	2050	2400	2850	3310	4000	
190		365	464	573	692	911	1160	1440	1760	2140	2490	2960	3440	4150	
200		381	484	598	722	947	1210	1500	1820	2220	2590	3060	3560	4300	
220															
240															
260															
280															
300															
320															
340															
360															
400															

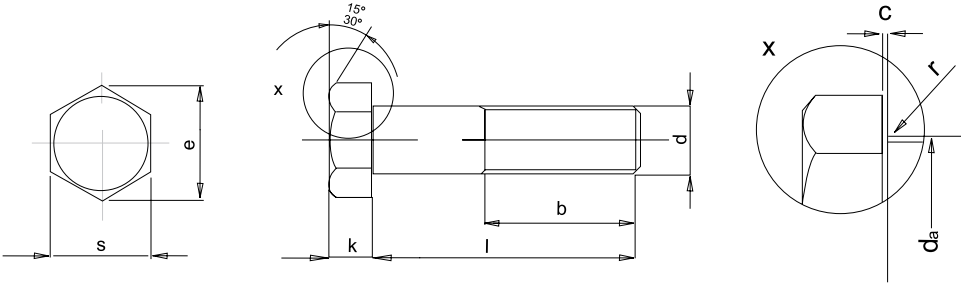

DIN 960

ALTI KÖŞE BAŞLI CİVATALAR İNCE DİŞ YARIM PASO
HEXAGON HEAD BOLTS WITH FINE PITCH THREAD
Kalite / Quality :5.6/5.8/ 8.8/10.9/12.9

TABLODAKİ TÜM DEĞERLER MİLMETRE OLARAK VERİLMİŞTİR. / ALL VALUES IN TABLE ARE GIVEN IN MILLIMETERS

d	M16X1,5	M18X2	M20X2	(M22x2)	(M24x2)	(M27x2)	M30x2	M33x2	M36x3	M39x3	M42x3	M45x3	M48x3	M52x3	M56X4
	-	M18X1,5	M20x1,5	M22x1,5	M24X1,5	-	-	-	-	-	-	-	-	-	-
b1	38	42	46	50	54	60	66	72	78	84	90	96	102	-	-
b2	44	48	52	56	60	66	72	78	84	90	96	102	108	116	124
b3	57	61	65	69	73	79	85	91	97	103	109	115	121	129	137
c	0,4	0,4	0,4	0,4	0,5	0,5	0,5	0,5	0,5	0,6	0,6	0,6	0,6	-	-
da max.	18,2	20,2	22,4	24,4	26,4	30,4	33,4	36,4	39,4	42,4	45,6	48,6	52,6	56,6	63
e m	26,75	30,14	33,53	35,72	39,98	45,63	51,23	55,8	61,61	66,96	72,61	78,26	83,91	89,56	95,07
min mg	26,17	29,56	32,95	35,03	39,55	45,2	50,85	55,37	60,79	66,44	72,09	77,74	83,39	89,04	94,47
k	10	12	13	14	15	17	19	21	23	25	26	28	30	33	35
r min.	0,6	0,6	0,8	0,8	0,8	1	1	1	1	1	1,2	1,2	1,6	1,6	2
s	24	27	30	32	36	41	46	50	55	60	65	70	75	80	85

THREAD SIZE / ANMA ÇAPİ	M16X1,5	M18X2	M20X2	(M22x2)	(M24x2)	(M27x2)	M30x2	M33x2	M36x3	M39x3	M42x3	M45x3	M48x3	M52x3	M56X4
-------------------------	---------	-------	-------	---------	---------	---------	-------	-------	-------	-------	-------	-------	-------	-------	-------

LENGHT / BOY 1000 ADETİN KG AĞIRLIĞI / MASS FOR 1.000 UNITS IN KG

50															
55	119														
60	127	169													
65	135	179	228												
70	143	189	240	293											
75	151	199	253	308	382										
80	159	209	265	323	410	553									
85	167	219	277	338	428	575									
90	175	229	290	353	445	597	740								
95	183	239	302	368	463	620	768								
100	191	249	314	383	481	642	796	1000							
110	217	269	339	413	517	687	851	1070	1310	1600					3650
120	233	289	363	443	552	732	906	1140	1390	1690	2000	2370			3840
130	249	308	387	473	588	777	962	1200	1470	1790	2110	2490	2920		4030
140	265	328	412	502	623	822	1020	1270	1550	1880	2220	2620	3060		4220
150	281	348	437	532	659	867	1070	1340	1630	1970	2330	2740	3200	3870	4410
160	296	368	461	562	694	912	1130	1400	1710	2070	2440	2870	3340	4040	4600
170	312	388	486	592	730	957	1180	1470	1790	2160	2550	2990	3480	4200	4790
180	328	408	510	621	765	1000	1240	1540	1870	2520	2660	3120	3620	4370	4980
190	344	428	535	651	800	1050	1290	1600	1950	2350	2770	3240	3760	4540	5170
200	360	448	560	681	836	1090	1350	1670	2030	2440	2880	3370	3900	4700	5360
220	390	488	608	740	907	1190	1460	1800	2190	2630	3100	3620	4180	5030	5740
240							1570	1930	2350		3320	3870	4460	5360	6120
260													4740	5960	6500
280															6880
300															7160

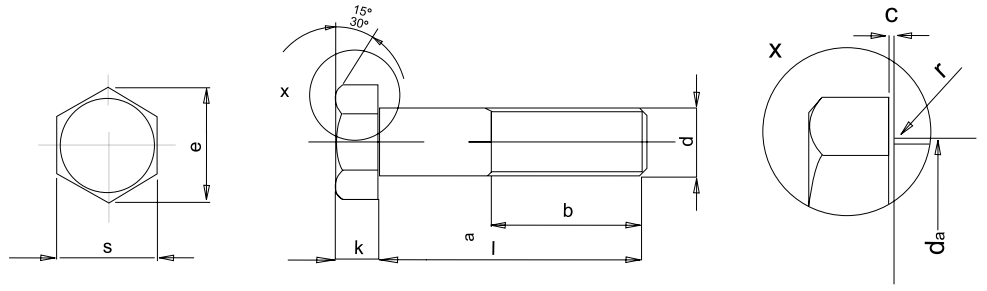

DIN 961

ALTİKÖŞE BAŞLI CIVATALAR İNCE DİŞ-TAM PASO

HEXAGON HEAD BOLTS WITH PITCH THREAD

Kalite / Quality : 5.6/5.8/ 8.8/10.9/12.9

TABLODAKİ TÜM DEĞERLER MİLMETRE OLARAK VERİLMİŞTİR. / ALL VALUES IN TABLE ARE GIVEN IN MILIMETERS

	M16X1,5	M18X2	M20X2	(M22x2)	(M24x2)	(M27x2)	M30x2	M33x2	M36x3	M39x3	M42x3	M45x3	M48x3	M52x3
d	-	M18x1,5	M20x1,5	M22x1,5	M24x1,5	-	-	-	-	-	-	-	-	-
c	0,40	0,40	0,40	0,40	0,50	0,50	0,50	0,50	0,50	0,60	0,60	0,60	0,60	-
da max.	18,20	20,20	22,40	24,40	26,40	30,40	33,40	36,40	39,40	42,40	45,60	48,60	52,60	56,60
e m	26,75	30,14	33,53	35,72	39,98	45,63	51,28	55,80	61,31	66,96	72,61	78,26	83,91	89,56
min mg	26,17	29,56	32,95	35,03	39,55	45,20	50,85	55,37	60,79	66,44	72,09	77,74	83,39	89,04
k	10,00	12,00	13,00	14,00	15,00	17,00	19,00	21,00	23,00	25,00	26,00	28,00	30,00	33,00
r min	0,60	0,60	0,80	0,80	0,80	1,00	1,00	1,00	1,00	1,00	1,20	1,20	1,60	1,60
s	24,00	27,00	30,00	32,00	36,00	41,00	46,00	50,00	55,00	60,00	65,00	70,00	75,00	80,00

THREAD SIZE / ANMA ÇAPI	M16X1,5	M18X2	M20X2	(M22x2)	(M24x2)	(M27x2)	M30x2	M33x2	M36x3	M39x3	M42x3	M45x3	M48x3	M52x3
LENGHT / BOY	1000 ADETİN KG AĞIRLIĞI / MASS FOR 1.000 UNITS IN KG													
50	106	143	185	226	287	386	512	650	805	1010	1210	1460	1740	2140
55	113	152	196	240	303	402	537	681	841	1050	1260	1520	1800	2220
60	120	161	208	253	319	427	563	712	877	1100	1310	1570	1870	2290
65	127	169	218	267	336	447	588	743	913	1140	1350	1630	1930	2370
70	134	178	229	280	352	467	613	774	949	1180	1400	1690	2000	2450
75	141	186	240	293	368	487	639	805	980	1220	1450	1740	2060	2520
80	148	196	252	307	384	507	664	836	1020	1270	1500	1800	2130	2600
85	155	205	262	321	400	527	690	867	1060	1310	1550	1860	2190	2680
90	162	213	273	335	415	547	715	898	1090	1350	1600	1910	2260	2760
95	169	222	285	347	432	567	741	929	1130	1390	1650	1970	2310	2600
100	176	230	296	361	448	587	766	960	1160	1440	1700	2030	2380	2910
110	190	248	318	388	481	627	817	1020	1230	1520	1800	2140	2510	3060
120	204	266	340	415	513	667	867	1080	1300	1600	1900	2260	2640	3220
130	218	284	362	442	546	707	918	1150	1370	1690	1990	2260	2640	3220
140	232	301	384	469	579	747	968	1210	1450	1770	2090	2480	2900	3530
150	245	319	406	495	611	787	1020	1270	1520	1860	2190	2600	3030	3680
160	259	337	428	522	643	827	1070	1330	1590	1940	2290	2710	3160	3830
170	273	355	450	549	675	867	1120	1390	1660	2030	2390	2820	3290	3990
180	287	373	472	576	707	907	1170	1460	1730	2110	2490	2940	3420	4140
190	301	391	494	603	739	947	1220	1520	1800	2200	2590	3050	3550	4300
200	315	409	516	630	771	987	1270	1580	1870	2280	2690	3170	3680	4460

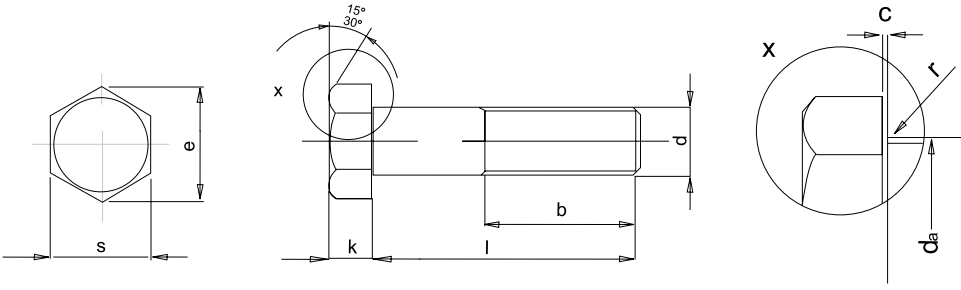

ASME B18 2.1

ALTI KÖŞE BAŞLI CİVATALAR UNC-UNF (TAM PASO / YARIM PASO)

HEXAGON HEAD BOLTS

Kalite / Quality : 5.6/5.8/ 8.8/10.9/12.9

TABLODAKİ TÜM DEĞERLER MİLİMETRE OLARAK VERİLMİŞTİR. / ALL VALUES IN TABLE ARE GIVEN IN MILIMETERS

THREAD SIZE / ANMA ÇAPI	İNÇ	5/8"	3/4"	7/8"	1"	1 1/8"	1 1/4"	1 1/2"
	MM	15,87	19,05	22,22	25,4	28,57	31,75	38,1
PARMAKTA DİŞ SAYISI	UNC	11	10	9	8	7	7	6
	UNF	18	16	14	12	12	12	12
	k	10,23	12,26	14,3	15,9	18,24	20,64	
	s	23,81	28,57	33,33	38,1	42,8	47,4	57,1
b	L<6" b1	38	44,5	51	57	63,5	70	82,5
	L>6" b2	44,5	51	57	63	70	76	89

1000 ADETİN KG AĞIRLIĞI / MASS FOR 1.000 UNITS IN KG

THREAD SIZE / ANMA ÇAPI	5/8"	3/4"	7/8"	1"	1 1/8"	1 1/4"	1 1/2"	
LENGHT / BOY								
INC	MM	15,87	19,05	22,22	25,4	28,57	31,75	38,1
2"	50,90	103,51	159,3	234	327			
2 1/4	57,15	113,26	173,41	256,5				
2 3/8	60,33	118,16	180,46					
2 1/2	63,50	123,06	187,52	269	369	635		
2 5/8	66,68	127,94	194,57					
2 3/4	69,85	132,81	201,62	394	517			
3"	76,20	142,61	215,73	306	418	549	712	
3 1/4	82,25	152,36	229,84	325	442	753		
3 1/2	88,90	162,16	243,94	343	467	608	789	
3 3/4	95,25	171,91	258,05					
4"	101,60	181,71	272,16	381	517	671	866	1280
4 1/4	107,95	191,48	286,26					
4 1/2	114,30	201,26	300,37	418	562	735	943	1386
4 3/4	120,65	211,03	314,48					
5"	127,00	220,81	328,58	454	612	794	1040	1494
5 1/4	133,35	230,58	342,69					
5 1/2	139,70	240,36	356,8	494	662	857	1118	1600
5 3/4	146,05	250,13	370,9					
6"	152,40	259,91	385,01	531	712	916	1195	1705
6 1/4	158,75	269,68	400,12					
6 1/2	165,10	279,45	415,23	567				
6 3/4	171,45	289,22	430,34					
7"	177,8	299,00	445,45	603	803			
7 1/4	184,15	308,77	460,56					
7 1/2	190,5	318,54	475,67					
7 3/4	196,85	328,31	490,78					
8"	203,2	338,08	505,89					

DIN 6914

ALTI KÖŞE BAŞLI AĞIR YÜK CİVATALARI
HEXAGON HEAD BOLTS HIGH-STRENGTH
Kalite / Quality : 8.8/10.9/12.9

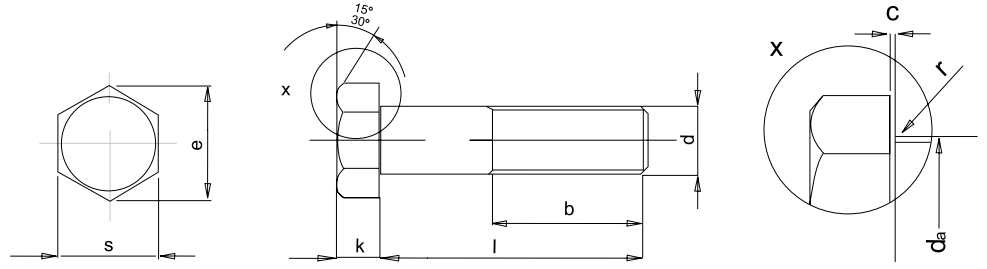

TABLODAKİ TÜM DEĞERLER MİLMETRE OLARAK VERİLMİŞTİR. / ALL VALUES IN TABLE ARE GIVEN IN MILIMETERS

THREAD SIZE / ANMA ÇAPI		M16	M20	M22	M24	M27	M30	M36>
PITCH / DIŞ ADIMI	P	2,00	2,50	2,50	3,00	3,00	3,50	4,00
HEAD HIGH / KAFA YÜKSEKLİĞİ	k	10	13,00	14,00	15,00	17,00	19,00	23,00
	+/-	0,75	0,90	0,90	0,90	0,90	1,05	1,05
	k'	6,47	8,47	8,47	9,87	11,27	12,56	15,36
HEAD WITH / ANAHTAR AĞZI	S	27	32,00	36,00	41,00	46,00	50,00	60,00
DIAGONEL/KÖŞEĞEN	e	29,56	35,03	39,55	45,20	50,85	55,37	66,44
THREAD LENGHT/DIŞ UZUNLUĞU	b1	26	31,00	32,00	34,00	37,00	40,00	48,00
	b2	28	33,00	34,00	37,00	39,00	42,00	50,00

b1: thread lenghts for bolts till 125mm / 125mm. Boya kadar olan civatalar için dış boyu

b2: thread lenghts for bolts between 125mm-200mm / 125mm-300mm. Boylar arasındaki civatalar için dış boyu

THREAD SIZE / ANMA ÇAPI	M16	M20	M22	M24	M27	M30	M36
LENGHT OF BOLT	1000 ADETİN KG AĞIRLIĞI / MASS FOR 1.000 UNITS IN KG						
50	121	194	249				
55	129	207	264				
60	137	219	279	353			
65	145	232	294	371			
70	153	244	309	389	519		
75	157	257	324	407	542	694	
80	165	269	339	425	564	723	
85	175	282	354	443	587	751	
90	181	288	363	449	609	779	1190
95	189	301	378	467	632	807	1290
100	197	313	393	485	645	832	1270
105	205	326	408	503	666	860	1310
110	213	338	423	521	687	888	1350
115	221	351	438	539	708	916	1390
120	229	363	453	557	729	944	1430
125	237	376	468	575	750	972	1470
130	245	388	483	593	771	1000	1500
135		400	498	611	792	1028	1540
140		413	513	629	813	1055	1580
145		425	528	647	834	1083	1620
150		438	543	665	855	1110	1660
155		450	558	683	876	1138	1700
160			573	700	897	1168	1740
165			588	718	918	1194	1780
170				736	939	1222	1820
175				754	960	1256	1860
180				772	981	1284	2000
185				790	1000	1312	2040
190				808	1020	1340	2080
195				826	1040	1368	2120
200					1060	1396	2160
220							
240							
260							
280							
300							
320							
340							
360							

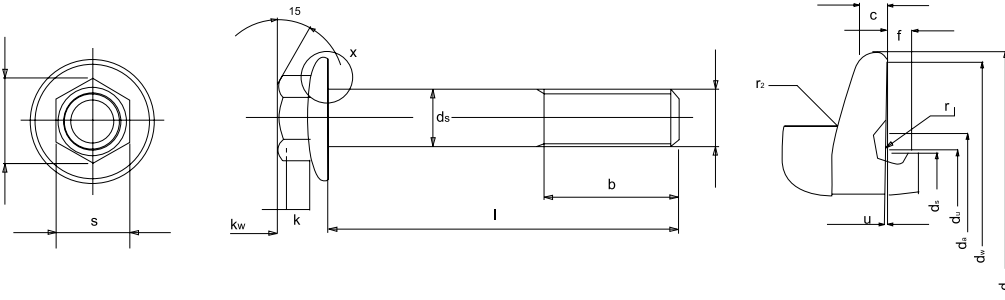

DIN 6921

FLANŞLI 6 KÖŞE CIVATALAR
HEXAGON BOLTS WITH FLANGE

TABLODAKİ TÜM DEĞERLER MİLMETRE OLARAK VERİLMİŞTİR. / ALL VALUES IN TABLE ARE GIVEN IN MILIMETERS

d		M16	M20>
		M16x1,5	M20x1,5
b	2	38	46
	3	44	52
c	min	2,4	3
da	max	17,7	22,2
dc	max	35	43
ds	max	16	20
	min	15,73	19,67
du	max	17,5	22
dw	min.	31,9	39,9
e	min.	23,15	29,87
f	max	3	4
k	max	14,4	17,1
kw	min	5,8	6,8
r1	min	0,6	0,8
r2	max	1	1,2
s	nom-max	21	27
	min	20,67	26,67
THREAD SIZE / ANMA ÇAPI		M16	M20
1000 ADETİN KG AĞIRLIĞI / MASS FOR 1.000 UNITS IN KG			
LENGHT OF BOLT			
50		116,6	196
55		126,7	
60		134,5	216
65		142,5	
70		150	237
75		158	
80		166	258
90		181	279
100		197	299
110		212	
120		228	340
130		242	
140		257	
150		273	
155			
160			
165			
170			
175			
180			
185			
190			
195			
200			
220			
240			
260			
280			
300			
320			
340			

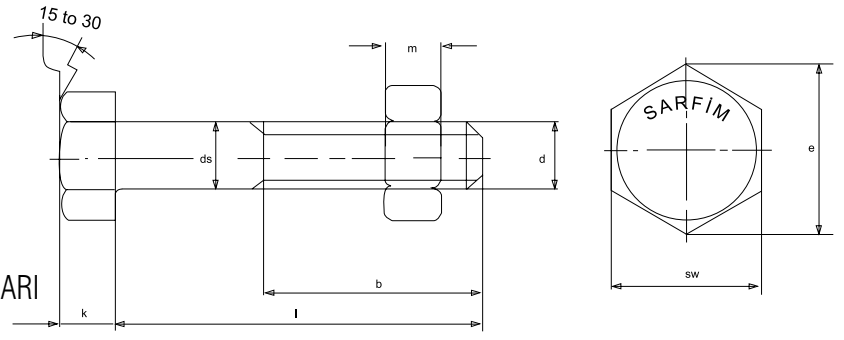

DIN 7990

ALTI KÖŞE BAŞLI ÇELİK KONSTRÜKSİYON CİVATALARI
HEXAGON HEAD BOLTS FOR STEEL STRUCTURES

Kalite / Quality : 8.8/10.9/12.9

TABLODAKİ TÜM DEĞERLER MİLMETRE OLARAK VERİLMİŞTİR. / ALL VALUES IN TABLE ARE GIVEN IN MILIMETERS

THREAD SIZE / ANMA ÇAPI	M16	M20	M22	M24	M27	M30->
PITCH / DIŞ ADIMI	P	2,00	2,50	2,50	3,00	3,50
HEAD HIGH / KAFA YÜKSEKLİĞİ	k	10	13	14	15	17
	+/-	0,18	0,22	0,22	0,22	0,35
HEAD WITH / ANAHTAR AĞZI	S	24	30	32	36	41
DIAGONEL/KÖŞEĞEN	e	26,17	32,95	35,03	39,55	45,2
HEIGHT OF NUT / SOMUN YÜK.	m	13	16	18	19,00	22
THREAD LEGHT / DIŞ UZUNLUĞU	b	21	23,5	25,5	26	29
THREAD SIZE / ANMA ÇAPI	M16	M20	M22	M24	M27	M30
LENGHT OF BOLT / boy	MASS FOR 1.000 UNITS IN KG / 1000 ADETİN AĞIRLIĞI					
50	141	247	311	387		
55	149	259	326	405		
60	157	272	341	423	585	
65	164	284	356	440	607	
70	172	296	370	458	630	
75	180	309	385	476	652	
80	188	321	400	494	675	899
85	196	334	415	511	697	917
90	204	346	430	529	720	945
95	212	358	445	547	742	972
100	220	371	460	565	765	1000
105	228	383	475	582	787	1030
110	236	395	490	600	810	1060
115	244	407	504	618	832	1090
120	252	420	519	636	855	1110
125	260	432	534	653	877	1140
130	267	445	549	671	900	1170
135	275	457	564	689	922	1200
140	283	469	579	707	945	1220
145	291	482	594	724	967	1250
150	299	494	608	742	990	1280
155		506	623	760	1010	1310
160		519	638	778	1030	1340
165		531	653	795	1050	1360
170		543	660	813	1080	1390
175		556	683	831	1100	1420
180			698	849	1120	1450
185			713	866	1140	1470
190			728	884	1170	1500
195			743	902	1190	1530
200			758	920	1210	1560
220						
240						
260						
280						
300						
320						
340						
360						
	M16	M20	M22	M24	M27	M30
	30,8	60,3	80,2	103	154	216

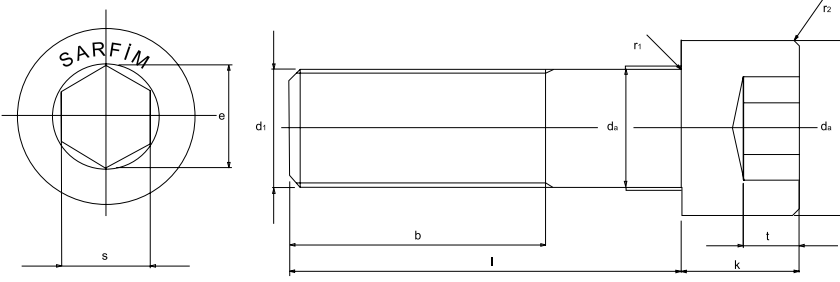

DIN 912

IMBUS CIVATA - ALTI KÖŞE SOKET BAŞLI VİDA
HEXAGON SOCKET HEAD CAP SCREWS

Kalite / Quality : 8.8/10.9/12.9

TABLODAKİ TÜM DEĞERLER MİLİMETRE OLARAK VERİLMİŞTİR. / ALL VALUES IN TABLE ARE GIVEN IN MILIMETERS

THREAD SIZE / ANMA ÇAPI	M16	M18	M20	M22	M24	M27	M30	M33	M36	
	M16x1,5	M18x2	M20x2	M22x2	M24x2	M27x2	M30x2	M33x2	M36X3	
PITCH / DİŞ ADIMI	P	2	2,5	2,5	2,5	3	3	3,5	3,50	4,00
HEAD HIGH / KAFA YÜKSEKLİĞİ	k	16	18	20	22	24	27	30	33	36
HEAD DIAMETER / KAFA ÇAPI	dk	24	27	30	33	36	40	45	50	54
SOCKET WITH / SOKET G	sw	14	14	17	17	19	19	22	24	27
SOCKET DIA / VSOKET Ç	e	16,3	16,3	19,8	19,8	22,1	22,1	25,6	27,9	31,4
SOCKET DİPTH / SOKET D	t	8	9	10	11	12	13,5	15,5	18	19
THREAD LENGHT / DİŞ UZUN.	b1	44	48	52	56	60	66	72	78	84
	b2	Tam Dişli / Fully threaded								

THREAD SIZE / ANMA ÇAPI	M16	M18	M20	M22	M24	M27	M30	M33	M36
LENGHT OF BOLT	MASS FOR 1.000 UNITS IN KG / 1000 ADETİN KG AĞIRLIĞI								
50	106	147	172	250	300	352	527	630	
55	114	157	183	263	316	374	554	665	870
60	122	167	195	276	330	396	581	700	910
65	130	177	207	291	345	418	608	735	950
70	138	187	220	306	363	440	635	770	990
75	146	197	232	321	381	462			
80	154	207	244	336	399	484	690	830	1070
90	170	227	269	366	435	529	745	900	1150
100	186	247	294	396	471	574	800	970	1230
110	202	267	319	426	507	619	855	1040	1310
120	218	287	344	456	543	664	910	1110	1390
130	234	307	369	486	579	709	965	1180	1470
140	250	327	394	516	615	754	1020	1250	1550
150	266	347	419	546	651	799	1080	1320	1630
160	282	363	444	576	687	844	1130	1390	1710
170			469	606	723	889	1190	1460	1790
180		403	494	636	759	934	1240	1530	1870
190				666	785	979	1300	1600	1950
200			541	696	820	1020	1350	1670	2030
220				756	903	1110	1460	1810	2190
240					975	1230	1570	1950	2250
260						1340	1680	2040	2410
280							1790	2180	2570
300							1900	2320	2730
320									
340									
360									

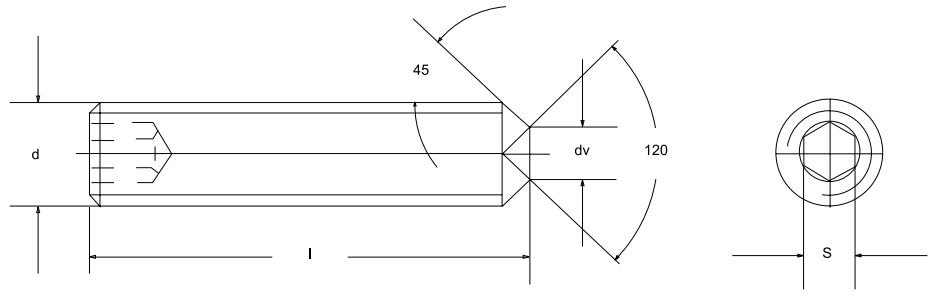

DIN 916

SETSKUR VIDA

HEXAGON SOCKET SET SCREWS WITH CUP POINT

TABLODAKİ TÜM DEĞERLER MİLİMETRE OLARAK VERİLMİŞTİR. / ALL VALUES IN TABLE ARE GIVEN IN MILIMETERS

THREAD SIZE / ANMA ÇAPI		M16	M18	M20	M24	M27	M30	M36
PITCH / DIŞ ADIMI	P	2,00	2,50	2,50	3,00	-	-	-
CUP POINT DIA / UÇ ÇAPI	dv	10,00	12,00	14,00	16,00	-	-	-
	min.	9,64	11,57	13,57	15,57	-	-	-
HEAD WIDTH / ANAHTAR AĞZI	sw	8,00	10,00	10,00	12,00	-	-	-
DIAGONAL / KÖŞEĞEN	e	6,40	7,20	8,30	10,00	-	-	-
SLOT DEPTH / ANAHTAR	t	10,00	11,00	12,00	15,00	-	-	-

THREAD SIZE / ANMA ÇAPI	M16	M18	M20	M24	M27	M30	M36
LENGHT OF BOLT	1000 ADETİN AĞIRLIĞI / MASS FOR 1.000 UNITS IN KG						
50			92,9	130			
60				160			
70							
80							
80							
100							

DIN 934

ALTİKÖŞE SOMUN

HEXAGON NUT

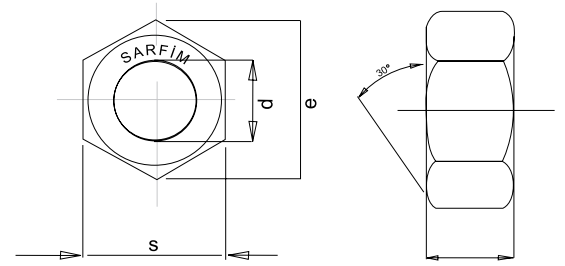

TABLODAKİ TÜM DEĞERLER MİLİMETRE OLARAK VERİLMİŞTİR. / ALL VALUES IN TABLE ARE GIVEN IN MILIMETERS

THREAD SIZE / ANMA ÇAPI		M36	M39	M42	M45	M48	M52	M56	M60	M64	M68	M72	M76	M80
PITCH / DIŞ ADIMI	P	4,00	4,00	4,50	4,50	5,00	5,00	5,50	5,50	6,00	6,00	-	-	-
HEAD WIDTH / ANAHTAR AĞZI	sw	55,00	60,00	65,00	70,00	75,00	80,00	85,00	90,00	95,00	100,00	105,00	110,00	115,00
DIAGONAL / KÖŞEĞEN	e	61,31	66,96	72,61	78,26	83,91	89,56	95,07	99,21	104,86	110,51	116,16	121,81	127,46
HEIGHT / YÜKSEKLİK	m	29,00	31,00	34,00	36,00	38,00	42,00	45,00	48,00	51,00	54,00	58,00	61,00	64,00
	min	27,00	28,50	32,40	34,40	36,40	40,40	43,40	46,40	49,10	52,10	56,10	59,10	62,10
WEIGHT / AĞIRLIK	gr/p	393,00	502,00	652,00	800,00	977,00	1.220,00	1.420,00	169,00	1980,00	2300,00	2670,00	3040,00	3440,00

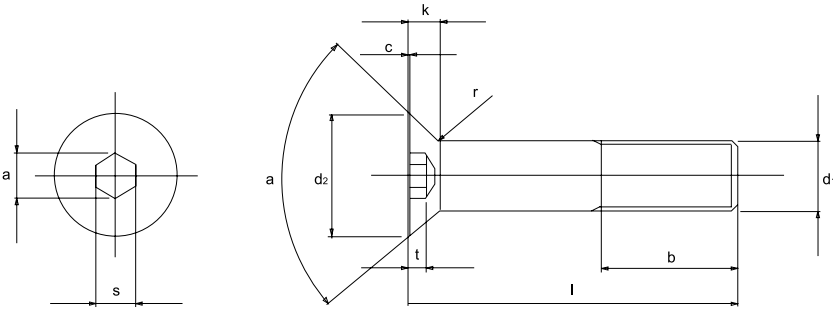

DIN 7991

ALTI KÖŞE SOKET HAVŞA BAŞLI VİDALAR (HB INBUS)
HEXAGON SOCKET COUNTERSUNK HEAD CUP SCREWS

TABLODAKİ TÜM DEĞERLER MİLİMETRE OLARAK VERİLMİŞTİR. / ALL VALUES IN TABLE ARE GIVEN IN MILIMETERS

THREAD SIZE / ANMA ÇAPI		M16	M18	M20	M22	M24	M27	M30	M33	M36
PITCH / DİŞ ADIMI	P	2,00	2,50	2,50	2,50	3,00				
HEAD HEIGH / KAFA YÜKSEKLİĞİ	k	7,5	8	8,5	13,1	14				
HEAD DIAMETER / KAFA ÇAPI	dk	30	33	36	36	39				
	min	29,48	32,38	35,38	35,38	38,38				
SOCKET WITH / SOKET G	s	10	12	12	14	14,00				
SOCKET DIAMETER / SOKET ÇAPI	m	11,43	13,72	13,72	16	16,00				
SOCKET DEPTH / SOKET DERİNLİĞİ	t	5,3	5,5	5,9	8,8	10,30				
THREAD LENGHT / DİŞ UZUNLUĞU	b1	38	42	46	50	54				
	b2	44	48	52	56	60				
	b3	57	61	65	69	73				

b1: thread lengths for bolts up to 125mm / 125mm. Boya kadar olan civatalar için diş boyu

b2: thread lengths for bolts between 125mm-200mm / 125mm-300mm. Boylar arasındaki civatalar için diş boyu

b3: thread lengths for bolts more than 200mm/ 200mm den uzun boylu civatalar için diş boyu

THREAD SIZE / ANMA ÇAPI			M16	M18	M20	M22	M24	M27	M30	M33	M36
LENGHT OF BOLT			MASS FOR 1.000 UNITS IN KG / 1000 ADETİN AĞIRLIĞI								
50	+/-	0,5	78,4		12		179				
60	+/-	0,6	91,7		143		209				
70	+/-	0,6	111		164		239				
80	+/-	0,6	127		200		269				
90	+/-	0,7	143		226		299				
100	+/-	0,7			253		340				
110											
120											
130											
140											
150											
160											
170											
180											
190											
200											
220											
240											
260											
280											
300											
320											
340											
360											

ASME B18 2.2

ALTI KÖŞE SOMUNLAR (UNC & UNF)
HEXAGON NUTS

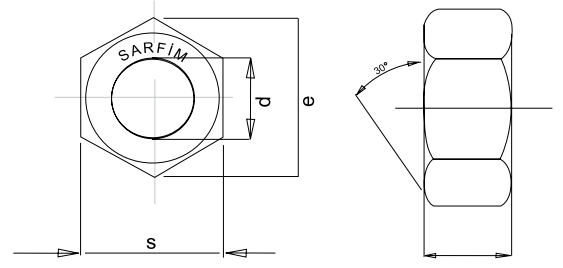

TABLODAKİ TÜM DEĞERLER MİLMETRE OLARAK VERİLMİŞTİR. / ALL VALUES IN TABLE ARE GIVEN IN MILIMETERS

THREAD SIZE / ANMA ÇAPI	d	1"	11/8	11/4	13/8	11/2	15/8	13/4	2"
PITCH / DIŞ ADIMI	UNC	8	7	7	6	6	5	5	4,5
	UNF	12	12	12	12	12			
HEAD WIDTH / ANAHTAR AĞZI	s	41	46	50	55	60	65	70	80
DIAGONEL / KÖŞEĞEN	e	47,3	53,1	57,7	63,5	69,3	75	80,8	92,4
HEIGHT / YÜKSEKLİK	m	20	22	25	28	30	32	35	40

1000 ADETİN AĞIRLIĞI / MASS FOR 1.000 UNITS IN KG

TREAD SIZE / ANMA ÇAPI / d	1"	11/8	11/4	13/8	11/2	15/8	13/4	2"
	139	196	259	354	443	560	709	1060

DIN 936

ALTİKÖŞE KONTRA SOMUNLAR
HEXAGON THIN NUTS

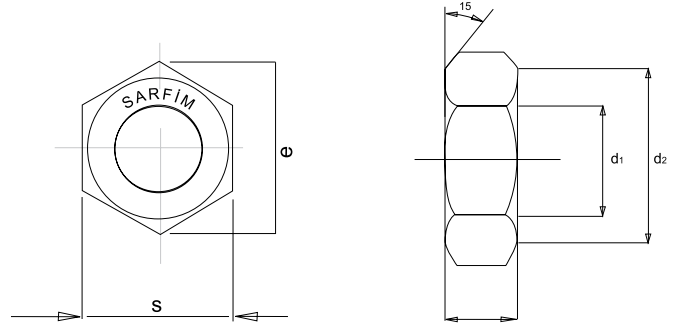

TABLODAKİ TÜM DEĞERLER MİLMETRE OLARAK VERİLMİŞTİR. / ALL VALUES IN TABLE ARE GIVEN IN MILIMETERS

THREAD SIZE / ANMA ÇAPI	d1	M16	M18	M20	M22	M24	M27	M30	M33	M36
PITCH / DIŞ ADIMI	P1	2,00	2,50	2,50	2,50	3,00	3,00	3,50	3,50	4,00
	P2	1,50	2,00	2,00	2,00	2,00	2,00	2,00	2,00	3,00
	P3	-	-	-	-	-	-	-	-	2,00
	P4	-	1,50	1,50	1,50	1,50	1,50	1,50	1,50	1,50
HEAD WIDTH / ANAHTAR AĞZI	s	24	27	30	32	36	41	46	50	55
DIAGONEL / KÖŞEĞEN	emax	26,75	30,14	33,53	35,72	39,98	45,63	51,28	55,8	61,31
HEIGHT / YÜKSEKLİK	M	8	9	9	10	10,00	12	12	14	14,00
	d2	21,6	24,3	27	28,8	32,40	36,9	41,4	45	49,50

THREAD SIZE / ANMA ÇAPI	d1	M16	M18	M20	M22	M24	M27	M30	M33	M36
1000 ADETİN AĞIRLIĞI / MASS FOR 1.000 UNITS IN KG										
P1		20,1	29,6	36,3	43,8	58	90	111	155	190
P2		19,6	28,9	35,4	42,8	55,8	87	110	150	180
P3		-	-	-	-	-	-	-	-	184
P4		-	28,3	35	42	55,2	86	109	148	181

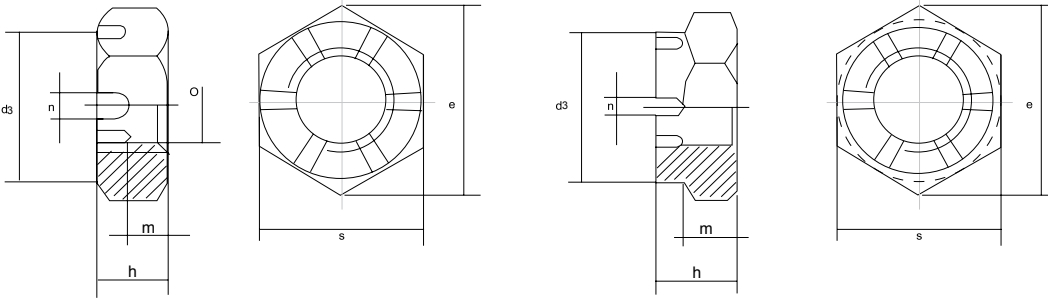

DIN 937

TAÇLI SOMUN
HEXAGON CASTLE NUT

TABLODAKİ TÜM DEĞERLER MİLİMETRE OLARAK VERİLMİŞTİR. / ALL VALUES IN TABLE ARE GIVEN IN MILIMETERS

THREAD SIZE ANMA ÇAPI (d1)	M6	M7	M8	M10	M12	M14	M16	M18	M20	M22	M24	M26	M27	M28	M30	M36	M39	M40	M42	M45	M48	M50
HEIGHT / YÜKSEKLİK (h)	6	7	8	9	10	11	12	13	13	15	15	17	17	17	18	20	22	22	23	25	25	27
DIAGONAL / KÖŞEĞEN (e min)	11,05	12,12	14,38	18,90	21,10	24,49	26,75	30,14	33,53	35,72	39,98	45,63	45,63	45,63	51,28	61,31	66,96	66,96	72,61	78,26	83,91	83,91
HEAD WIDTH / ANAHTAR AĞZI (s)	10	11	13	17	19	22	24	27	30	32	36	41	41	41	46	55	60	60	65	70	75	75
n	2	2	2,5	2,5	3,5	3,5	4,5	4,5	4,5	5,5	5,5	5,5	5,5	5,5	7	7	7	7	9	9	9	9
m	3,5	4	4,5	5	6	7	7	8	8	9	9	11	11	11	11	13	13	13	14	16	16	18
d3	-	-	-	-	17	19	22	25	28	30	34	38	38	38	42	50	55	55	58	62	65	65

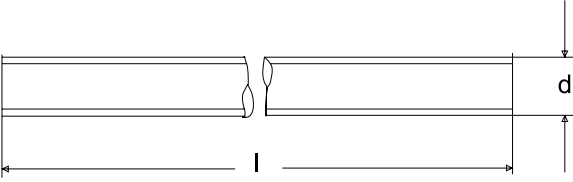

DIN975

GIJON
THEREADED RODS

ÇAP / DIAMETER (d)	LENGHT / UZUNLUK (l)	1000 ADETİN KG AĞIRLIĞI/ MASS FOR 1.000 UNITS INGR)
M16 (M16x1,5)	1000 MM	1330
M18 (M18x1,5)	1000 MM	1650
M20 (M20x1,5)	1000 MM	2080
M22 (M22x1,5)	1000 MM	2540
M24 (M24x2)	1000 MM	3000
M27 (M27x2)	1000 MM	3850
M30 (M30x2)	1000 MM	4750
M33 (M33x2)	1000 MM	5900
M36 (M36x3)	1000 MM	6900

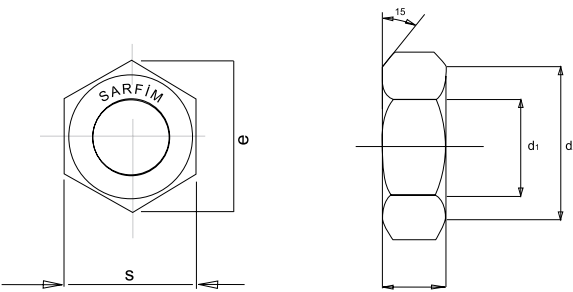

DIN 6915

ALTI KÖŞE AĞIR YÜK SOMUNU
HIGH/ STRENGTH HEXAGON NUT

THREAD SIZE / ANMA ÇAPI		M12	M16	M20	M22	M24	M27	M30	M36
PITCH / DİŞ ADIMI	P1	1,75	2,00	2,50	2,50	3,00	3,00	3,50	4,00
HEAD WIDTH / ANAHTAR AĞZI	sw	22,00	27,00	32,00	36,00	41,00	46,00	50,00	60,00
DIAGONAL / KÖŞEĞEN	e	23,91	29,56	35,03	39,55	45,20	50,85	55,37	66,44
HEIGHT / YÜKSEKLİK	h	10,00	13,00	16,00	18,00	19,00	22,00	24,00	29,00
	min	9,64	23,30	14,90	16,90	17,70	20,70	22,70	27,70
WEIGHT / AĞIRLIK		23,30	44,80	73,90	104,00	155,00	224,00	300,00	515,00



DIN 7991 / DIN 6914 / DIN 6915 / DIN 961 / DIN 960 / DIN 975 / DIN 936 / DIN 916 / ASA B18.2.1 / ASA B18.2.2 SOMUN / DIN 937 / DIN 931 / DIN 933 / DIN 934 /



SARFİM OTOMOTİV İNŞAAT SANAYİ VE TİCARET A.Ş.

ADRES : BÜSAN ÖZEL ORGANİZE SANAYİ 6. SOKAK NO:20 42300 KARATAY - KONYA / TÜRKİYE

TEL : +90 332 345 10 60

FAX : +90 332 345 10 62

E-MAIL : export@sarfim.com